



The product shown may differ from standard configuration.

PRIMO® XXM

Standard Seat with Mechanical Suspension



PRIMO® XXM

Technical data

Standard seat

The Primo XXM has an easy-to-use lever for optimally setting the suspension to the driver's weight within the range between 45 and 170 kg. Especially when a vehicle is used by multiple drivers, it's important for unpracticed users to be able to quickly and intuitively perform this important setting. The extra-high backrest, in conjunction with a lumbar support, bolsters the back and ensures an even more comfortable ride. The Primo XXM is equipped with an operator presence switch as well as a duosensitive ELR-belt system as standard.

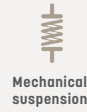

Mechanical suspension



Mechanical lumbar support



Manual weight adjustment

Features

	PRIMO® XXM	PRIMO® XXM	PRIMO® XXM
ARTICLE NO.			
Fabric	1293475		
Imitation leather	1106231		
STANDARD FEATURES			
Shock absorber, nonadjustable	●		
Suspension, mechanical	●		
Suspension stroke, 80 mm	●		
1 Weight adjustment, manual, 45-170 kg	●		
2 Fore/aft adjustment, 210 mm	●		
3 Lumbar support, mechanical	●		
4 Adjustable backrest angle	●		
		5 ELR-belt system, duosensitive	●
		Seat cushion width	450 mm
		Operator presence switch (OPS)	●
		OPTIONAL FEATURES	
		6 Document box	○
		7 Armrests, adjustable angle, 60 mm x 320 mm	○
		Fore/aft isolator*	○
		9 Seat heating	○

* Fore/aft isolator not for earth-moving machinery

Measurements (installation dimensions)

● STANDARD FEATURES ○ OPTIONAL FEATURES

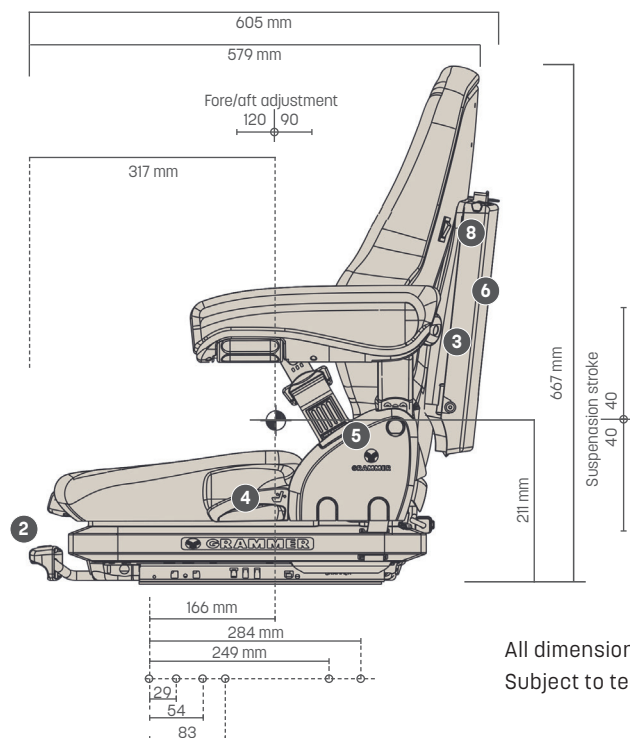
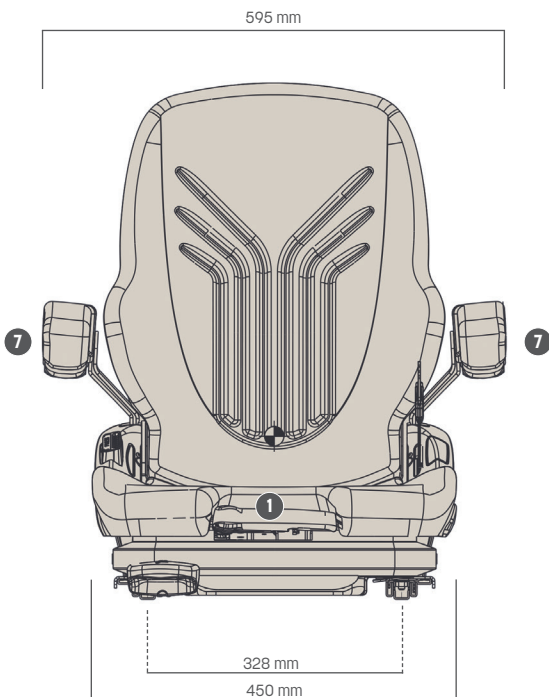

All dimensions in mm.
Subject to technical changes.