



PRIMO[®] XXM

Standard Seat with
Mechanical Suspension



GRAMMER

TECHNICAL DATA

PRIMO® XXM

The Primo XXM has an easy-to-use lever for optimally setting the suspension to the driver's weight within the range between 45 and 170 kg. Especially when a vehicle is used by multiple drivers, it's important for unpracticed users to be able to quickly and intuitively perform this important setting. The extra-high backrest, in conjunction with a lumbar support, bolsters the back and ensures an even more comfortable ride.



Mechanical Suspension



Mechanical Lumbar Support



Manual Weight Adjustment

Features ● Standard ○ Optional

	PRIMO® XXM
Article no. fabric	1293475
Article no. imitation leather	1106231
Shock absorber nonadjustable	●
⚙️ Suspension	
Mechanical suspension	●
Suspension stroke 80 mm	●
① Weight adjustment 45 - 170 kg	
Manual (mechanical)	●
② Fore/aft adjustment 210 mm	●
③ Lumbar support	
Mechanical	●

	PRIMO® XXM
④ Adjustable backrest angle	●
⑤ Restraint system	●
Seat cushion width	450 mm
Operator presence switch (OPS)	●
OPTIONAL FEATURES	
⑥ Document box	○
⑦ Armrests height-adjustable	○
Fore/After isolator*	○
⑧ Seat heating	○

* Force/after isolator not for earth-moving machinery

Measurements (installation dimensions)

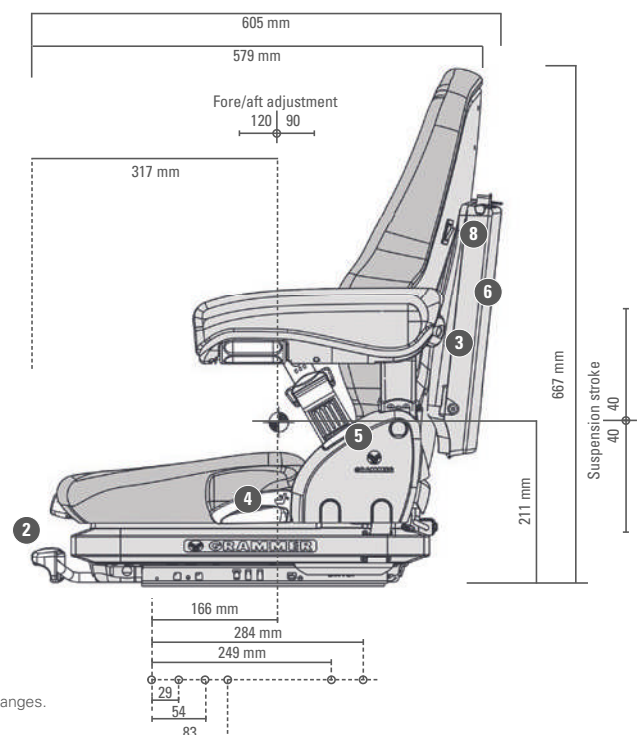
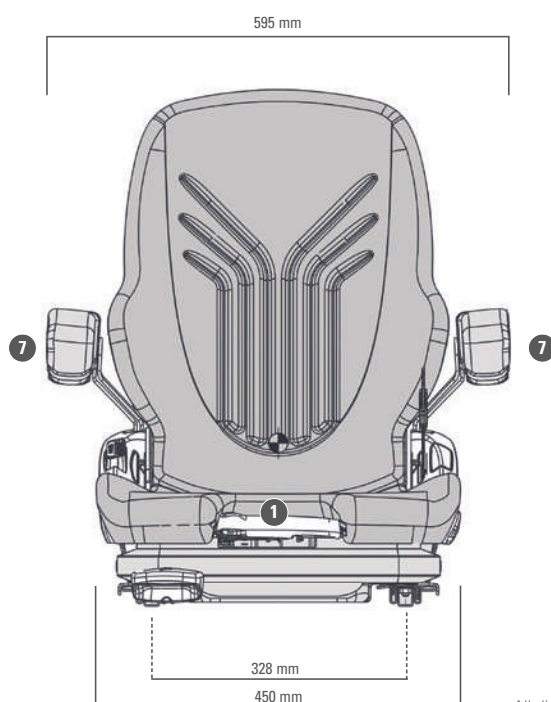

All dimensions in mm.
Subject to technical changes.